



Operating instructions
Temperature transmitter with display

GB

TDxxxx

80234348 / 01 02 / 2021

Contents

1	Preliminary note	3
1.1	Symbols used	3
1.2	Warnings used	3
2	Safety instructions.....	3
3	Intended use	4
4	Function	4
4.1	Analogue output.....	4
4.2	IO-Link	5
5	Installation.....	6
5.1	Use in hygienic areas according to 3-A	6
5.2	Use in hygienic areas to EHEDG.....	7
5.3	Units with clamp process connection.....	9
5.4	Units with G $\frac{1}{2}$ sealing cone process connection	9
5.4.1	Flush mount hygienic zero-leak using PEEK sealing	9
5.4.2	Flush mount zero-leak using metal-to-metal seal	10
5.5	Units for process adaptation via clamping ring	10
6	Electrical connection	11
7	Operating and display elements	12
8	Parameter setting.....	13
8.1	Adjustable parameters	13
9	Operation	14
10	Technical data.....	14
10.1	Temperature resistance	14
11	Maintenance, repair and disposal	14
12	Factory setting	15

1 Preliminary note

You will find instructions, technical data, approvals and further information using the QR code on the unit / packaging or at www.ifm.com.

1.1 Symbols used

- ✓ Requirement
- ▶ Instructions
- ▷ Reaction, result
- [...] Designation of keys, buttons or indications
- Cross-reference



Important note

Non-compliance may result in malfunction or interference.



Information

Supplementary note

1.2 Warnings used



CAUTION

Warning of personal injury

- ▷ Slight reversible injuries may result.

2 Safety instructions

- The unit described is a subcomponent for integration into a system.
 - The system architect is responsible for the safety of the system.
 - The system architect undertakes to perform a risk assessment and to create documentation in accordance with legal and normative requirements to be provided to the operator and user of the system. This documentation must contain all necessary information and safety instructions for the operator, the user and, if applicable, for any service personnel authorised by the architect of the system.
- Read this document before setting up the product and keep it during the entire service life.

- The product must be suitable for the corresponding applications and environmental conditions without any restrictions.
- Only use the product for its intended purpose (→ Intended use).
- Only use the product for permissible media.
- If the operating instructions or the technical data are not adhered to, personal injury and/or damage to property may occur.
- The manufacturer assumes no liability or warranty for any consequences caused by tampering with the product or incorrect use by the operator.
- Installation, electrical connection, set-up, operation and maintenance of the product must be carried out by qualified personnel authorised by the machine operator.
- Protect units and cables against damage.

3 Intended use

The unit monitors liquids and gases.

The unit detects the medium temperature and converts it into an analogue output signal.

4 Function

4.1 Analogue output

The unit provides an analogue signal proportional to the process value.

The analogue signal is invertible:

- 4...20 mA with setting [OU] = I
- 20...4 mA with setting [OU] = Ineg

The measuring range is scalable: The parameters [ASP] and [AEP] allow for the measuring range to be limited.



Minimum distance between ASP and AEP = 5 °C or 9 °F.

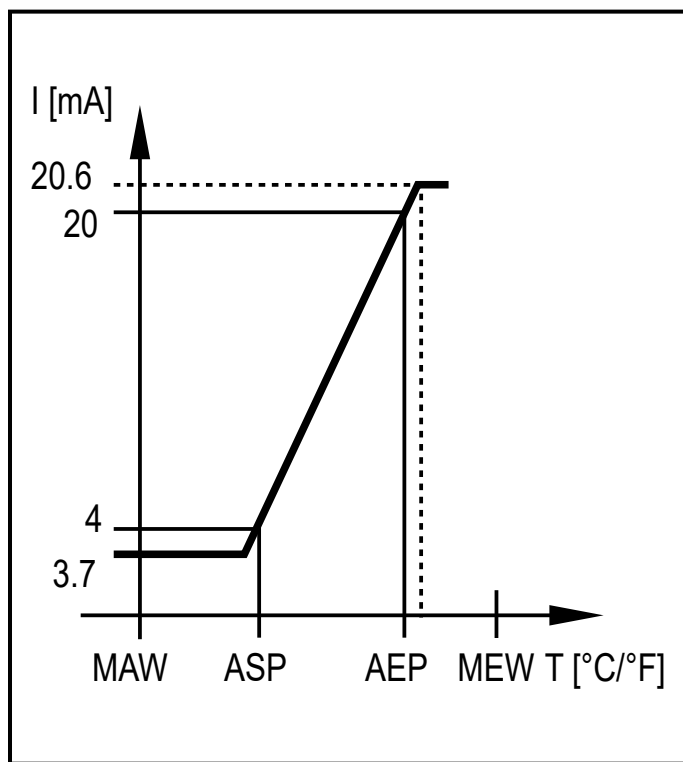
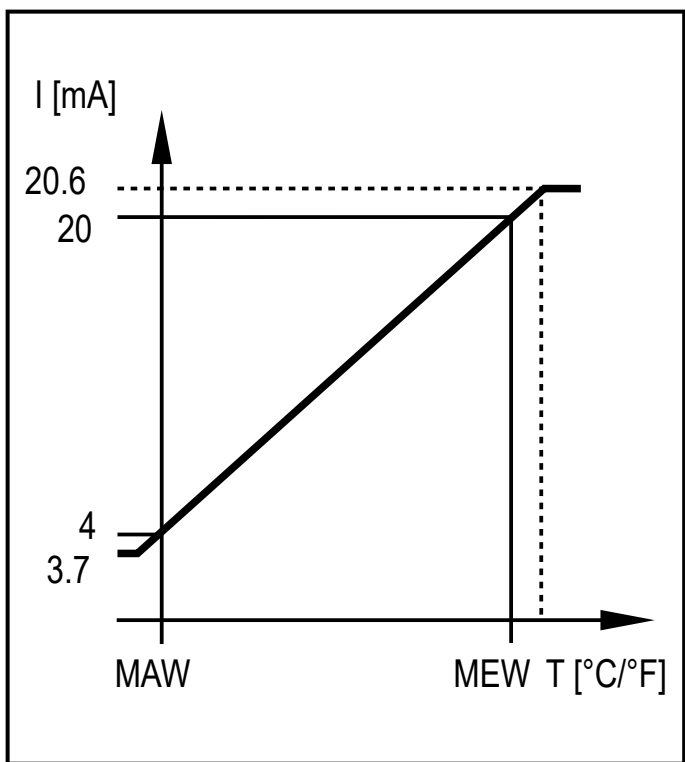

Fig. 1: Maximum measuring range at [OU] = I

Fig. 2: Scaled measuring range at [OU] = I

MAW: Initial value of the measuring range
 MEW: Final value of the measuring range

ASP: Analogue start value
 AEP: Analogue end value

Within the measuring range, the output signal is between 4 and 20 mA. If the temperature value is outside the limits of the measuring range, the following signal is provided:

	Output signal at [OU] = I	Output signal at [OU] = In-eg
Temperature > AEP	20...20.6 mA	4...3.7 mA
Temperature > MEW	20.6 mA	3.7 mA
Temperature < ASP	4...3.7 mA	20...20.6 mA
Temperature < MAW	3.7 mA	20.6 mA

In case of an internal fault, the output signal reacts according to the parameter set in [FOU] (3.5 mA or 21.1 mA).

4.2 IO-Link

This unit has an IO-Link communication interface which enables direct access to process and diagnostic data. In addition it is possible to set the parameters of the unit while it is in operation. Operation of the unit via the IO-Link interface requires an IO-Link master.

With a PC, suitable IO-Link software and an IO-Link adapter cable, communication is possible while the system is not in operation.

The IO-DDs necessary for the configuration of the unit, detailed information about process data structure, diagnostic information, parameter addresses and the necessary information about the required IO-Link hardware and software can be found at www.ifm.com.

The IO-Link interface provides the following functions using suitable hardware and software:

- Remote parameter setting of the unit.
- Noise-immune signal transmission without measured value losses.
- Transmission of the parameter settings to a replaced unit or to other units of the same type.
- Display of error and event messages.
- Paperless logging of parameter sets, process values and diagnostic information.
- Evaluation of the process values and diagnostic data via IO-Link master.

5 Installation





CAUTION

During installation or in case of mechanical failure, high pressure or hot media can leak from the system.

- ▷ Risk of injury caused by pressure or burns.
 - ▶ Ensure that the system is free of pressure during installation.
 - ▶ Ensure that no media can leak at the mounting location during installation.
-

5.1 Use in hygienic areas according to 3-A

- ▶ Secure clamp sensors with a suitable clamp.
- ▶ Ensure that the installation of the unit in the system complies with 3-A guidelines.
- ▶ Use only process adapters with 3-A certification and marked with the 3-A symbol (→ Accessories at www.ifm.com).

- ▶  For use according to 3-A, take note of the corresponding regulations for cleaning and maintenance.
- ▶  Not suitable for systems that have to meet the criteria of E1.2 / 63-03 of the 3-A standard 63-03.

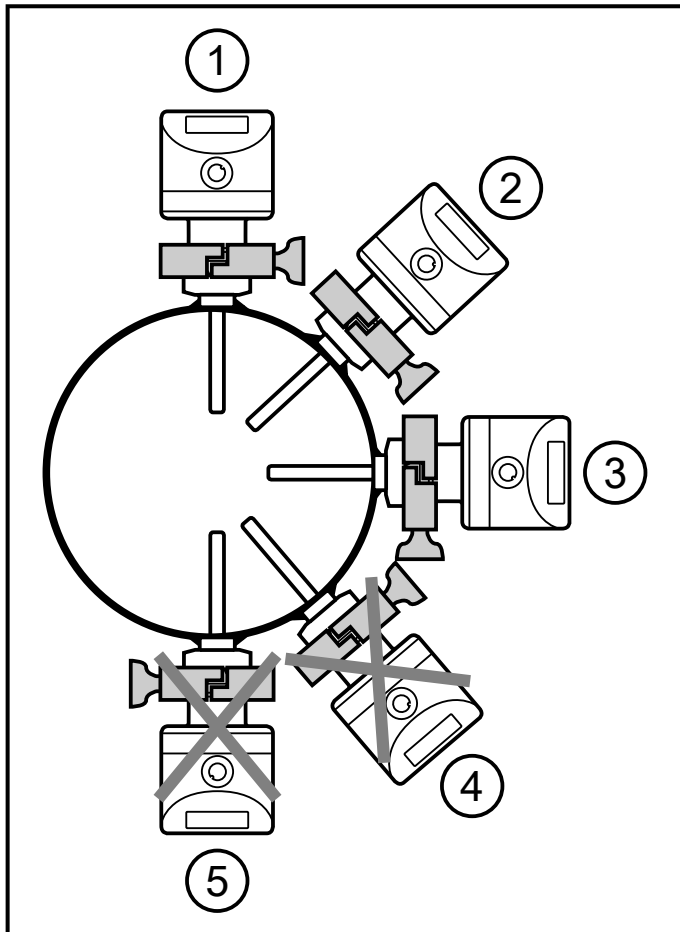

- ▶ The positioning of the sensor must be observed to ensure the mounting adapter will self-drain: Do not install the unit in positions 4 and 5.

GB

Fig. 3: Installation position for 3-A certification

5.2 Use in hygienic areas to EHEDG

- ▶  The sensor is suited for CIP (clean in place) when installed correctly.
 - ▶ Observe the application limits (temperature and material resistance) according to the data sheet.
- ▶ Ensure that the installation of the unit in the system complies with EHEDG.
- ▶ Use self-draining installation.
- ▶ Only use process adapters permitted according to EHEDG with special seals required by the EHEDG position paper.
- ▶ Leakage ports must be clearly visible and must be installed facing downwards for vertical pipes.

- ▶ For any structures in a tank, direct water jet cleaning and cleaning of any dead spaces must be possible.
- ▶ Adhere to the dimensions shown in the following figure to avoid dead spaces that cannot be cleaned effectively:
 $L < (D - d)$.

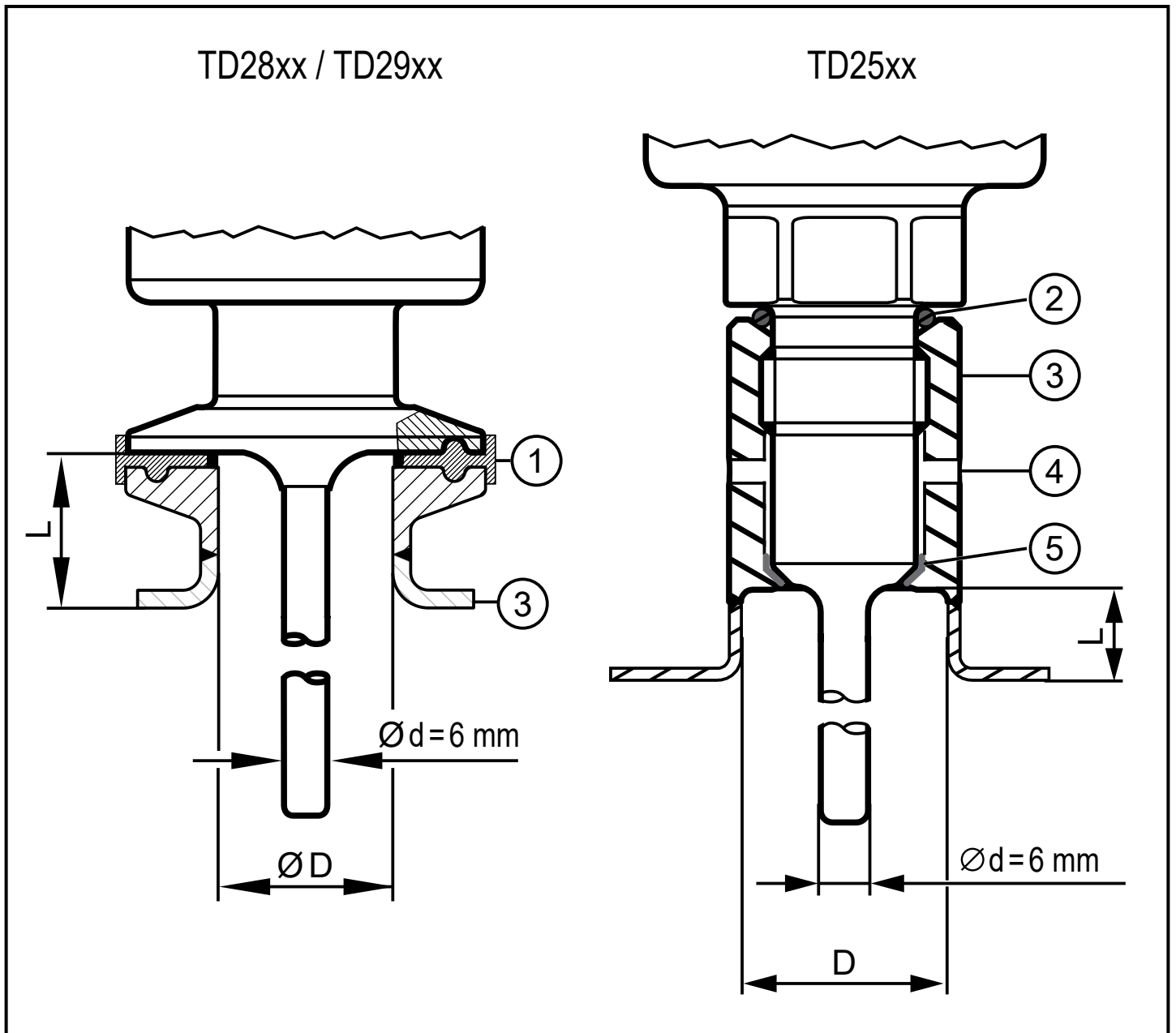

Fig. 4: Mounting dimensions for EHEDG approval

- 1: Sealing ring in accordance with EHEDG position paper
- 2: Sealing ring between the housing and the process connection (E43911)
- 3: Adapter
- 4: Leakage port
- 5: PEEK sealing (E43911)

5.3 Units with clamp process connection

The one-piece units of design TD28xx with clamp 1.5" and of design TD29xx with clamp 2" are best suited for a hygienic installation.



Adhere to the installation instructions for use in hygienic areas according to 3-A or EHEDG.

5.4 Units with G $\frac{1}{2}$ sealing cone process connection

The units of design TD25xx can be adapted to standard process connections using two sealing versions. The following applies to both sealing versions:

- ▶ Only use accessories from ifm electronic. The optimum function is not ensured when using components from other manufacturers.
- ▶ Observe the instructions of the adapter.

Use PEEK sealing for 3-A and EHEDG-conform sensor installation.



E43911 (PEEK sealing and sealing ring between housing and process connection) is not supplied with the unit but must be ordered separately.

- ▶ Adhere to installation instructions of E43911.



The sealing ring between the housing and the process connection can compensate for tolerances and provides protection against the ingress of media in the thread area.

The sealing ring between the housing and the process connection cannot compensate for the system pressure.

5.4.1 Flush mount hygienic zero-leak using PEEK sealing

- ▶ Insert the PEEK sealing.
 - The PEEK sealing is suited for use in hygienic installations to EHEDG and 3-A.
 - The PEEK sealing is long-term stable and maintenance-free.
 - When the PEEK sealing is mounted several times, check and replace it if necessary.
 - The PEEK sealing has been rated for ifm adapters with end stop towards the medium.
- ▶ Use adapters with leakage ports.
- ▶ Screw the sensor into the adapter. Recommended tightening torque 20 Nm.

 Adhere to the installation instructions for use in hygienic areas according to 3-A or EHEDG.

5.4.2 Flush mount zero-leak using metal-to-metal seal

 A long-term stable, maintenance-free fitting without bug traps in the metal-to-metal sealing is only valid for once-only mounting.

▶ Do not use the PEEK sealing.

▶ Screw the sensor into the adapter. Recommended tightening torque 20 Nm.

5.5 Units for process adaptation via clamping ring

The units of design TD22xx can be mounted in the pipe or in the tank directly in contact with the medium via a clamping ring adapter.

Mounting examples:

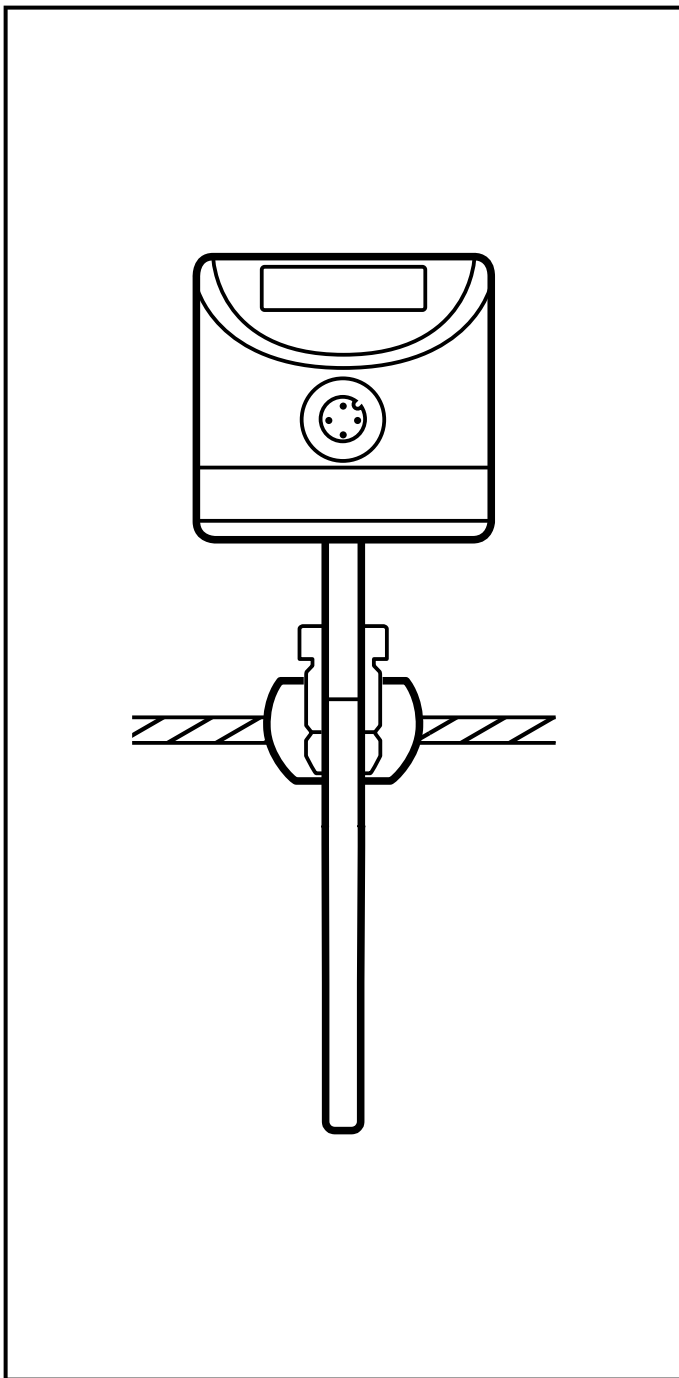

Fig. 5: Direct installation (e.g. with adapter E30407)

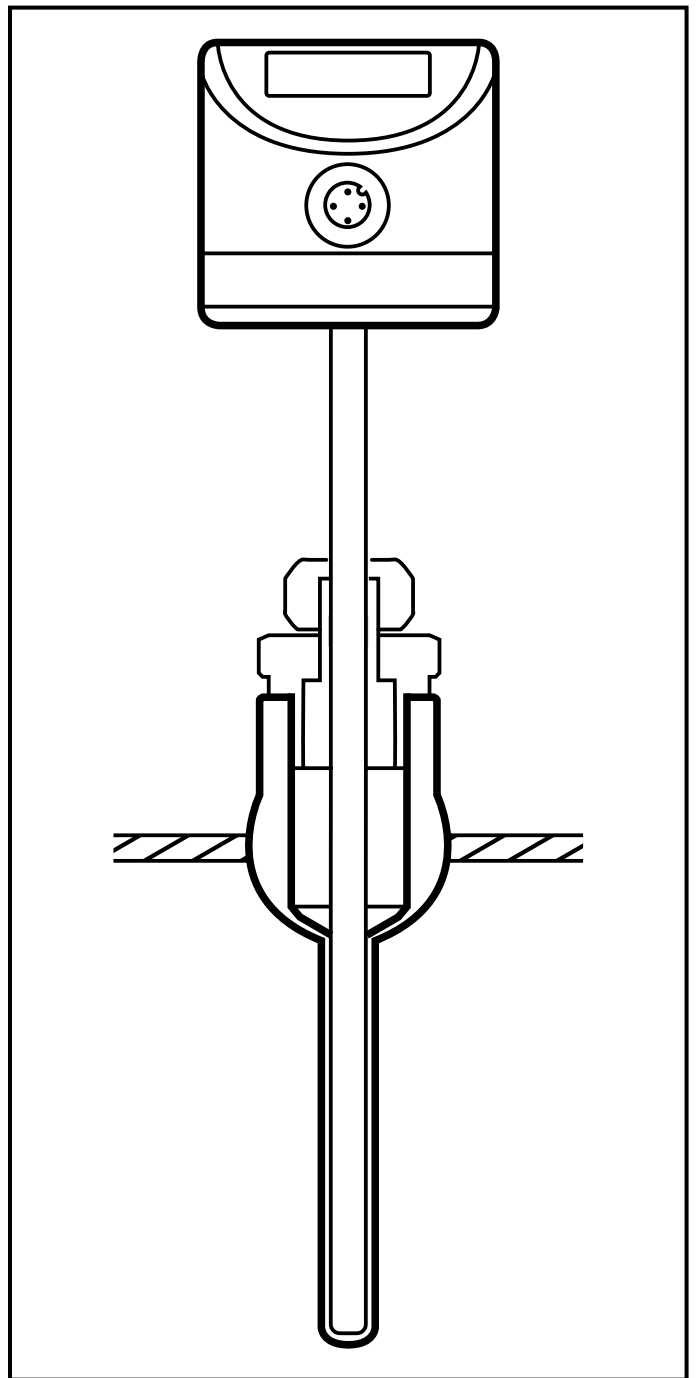

Fig. 6: Installation with protective tube (e.g. with adapter E37421)

6 Electrical connection



The device must be connected by a qualified electrician.

Observe the national and international regulations for the installation of electrical equipment.

Voltage supply according to EN 50178, SELV, PELV.

- ▶ Disconnect power.
- ▶ Connect the unit as follows:

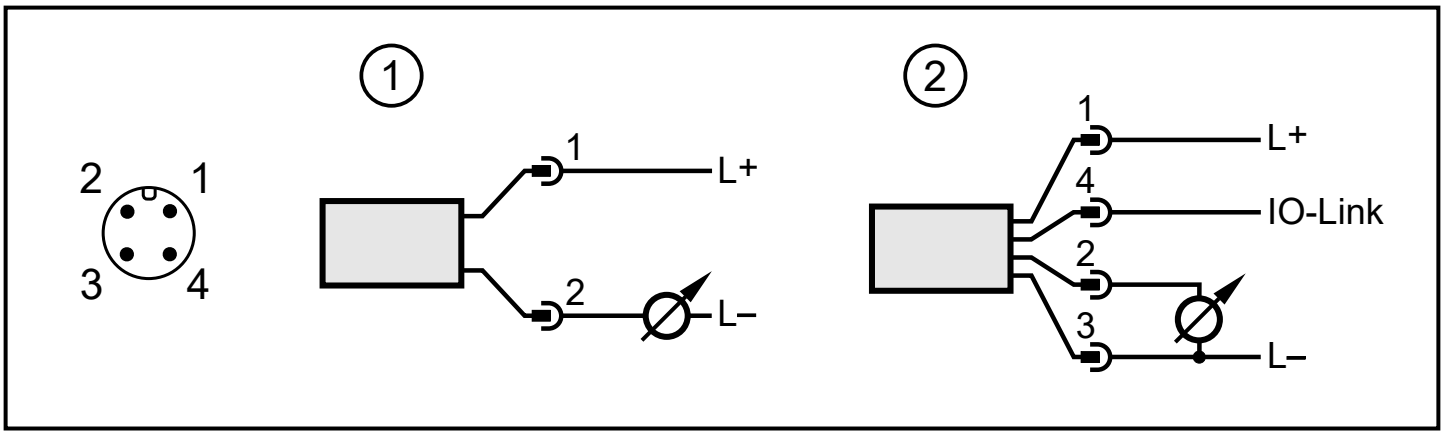

Fig. 7: Wiring diagram

Operation as 2-wire unit (1)

Pin	Connection
1	L+
2	Analogue signal temperature

Operation as 4-wire unit (2)

Pin	Connection
1	L+
2	Analogue signal temperature
3	L-
4	IO-Link

7 Operating and display elements

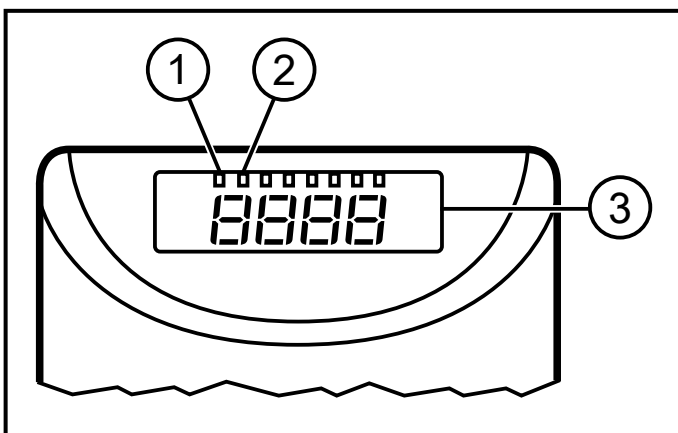

- 1: Current temperature in °C
- 2: Current temperature in °F
- 3: 4-digit alphanumeric display

Fig. 8: Operating and display elements

8 Parameter setting

Using an IO-Link capable parameter setting tool, the following options are available:

- Reading current process values.
 - Reading, changing and saving current parameter settings and transmitting them to other units of the same type.
- Connect the unit via the IO-Link interface to a PC or PLC with suitable parameter setting software.



You will find all information about the required IO-Link hardware and software at www.ifm.com.

GB

8.1 Adjustable parameters

Parameter	Description	
OU2	<ul style="list-style-type: none">• I: 4...20 mA• Ineg: 20...4 mA	
ASP2	Analogue start point	
	For OU2 = I	Measured temperature value at which 4 mA is provided.
	For OU2 = Ineg	Measured temperature value at which 20 mA is provided.
AEP2	Analogue end point	
	For OU2 = I	Measured temperature value at which 20 mA is provided.
	For OU2 = Ineg	Measured temperature value at which 4 mA is provided.
COF	Zero-point calibration Setting range: ± 10 °C in steps of 0.1 °C. The internal measured value "0" is shifted by this value.	
FOU2	Behaviour of the output in case of an internal fault. <ul style="list-style-type: none">• On: The analogue signal goes to 21.1 mA.• OFF: The analogue signal goes to 3.5 mA.	
Uni	Unit of measurement for medium temperature: °C or °F.	

Parameter	Description
diS	Display refresh rate: <ul style="list-style-type: none"> • d1: update of the measured values every 50 ms. • d2: update of the measured values every 200 ms. • d3: update of the measured values every 600 ms. Display orientation: <ul style="list-style-type: none"> • rd: Display rotated by 180°.

9 Operation

After power-on, the unit is in the normal operating mode.

The current temperature value is displayed.

10 Technical data

Technical data and scale drawing at www.ifm.com.

10.1 Temperature resistance

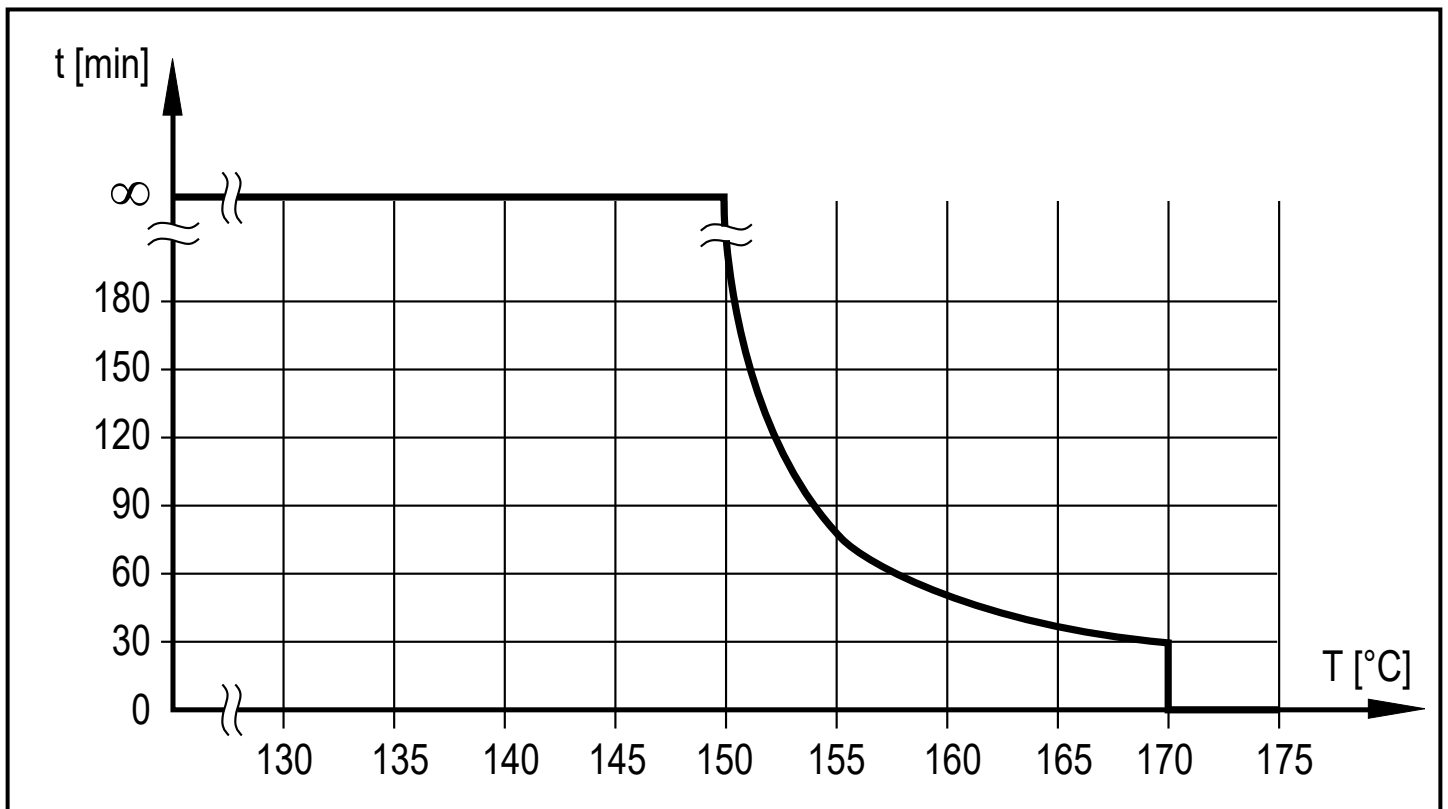

Fig. 9: Maximum operation time depending on the medium temperature

11 Maintenance, repair and disposal

The operation of the unit is maintenance-free.

Only the manufacturer is allowed to repair the unit.

- ▶ After use dispose of the device in an environmentally friendly way in accordance with the applicable national regulations.

12 Factory setting

Parameter	Factory setting	User settings
OU2	I	
COF	0	
FOU2	OFF	
diS	d1 Display not rotated	
ASP2	→ Technical data at www.ifm.com	
AEP2		
Uni		

GB